

1.5 Single components for automation and testing technology

Special module of the LKV-12 model series

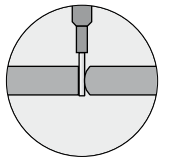

Pneumatic bonding for single conductors with isolated/non-isolated ring cable lugs

Function

The contact is made by inserting the line into the bonding outlet. The process is triggered by a control tappet which will be pressed down approx. 1 mm by the conductor. Bonding of the conductor is performed by a clamping piston connecting line and housing. Bonding is opened by interrupting the air supply using the LKV opening button, the magnetic valve, the air-operated button, foot-operated valve, etc.

Technical features

- Quick and safe bonding
- Possibility of correction using the LKV opening button in case of wrong assignment
- Simultaneous release of all connections
- Suitable for transferring higher and lower currents/voltages
- Easy assembly

Technical data

- Compressed air supply, filtered and dry air ~ 6 bar
- Air plug, 3 mm hose diameter (other plugs upon request)
- Electrical connection with flat-blade connection 6.3 x 0.8 mm
- Operating force 0,8 – 1,0 N
- Clamping force 15 – 20 N
- Dimension 60 x 25 x 12 mm

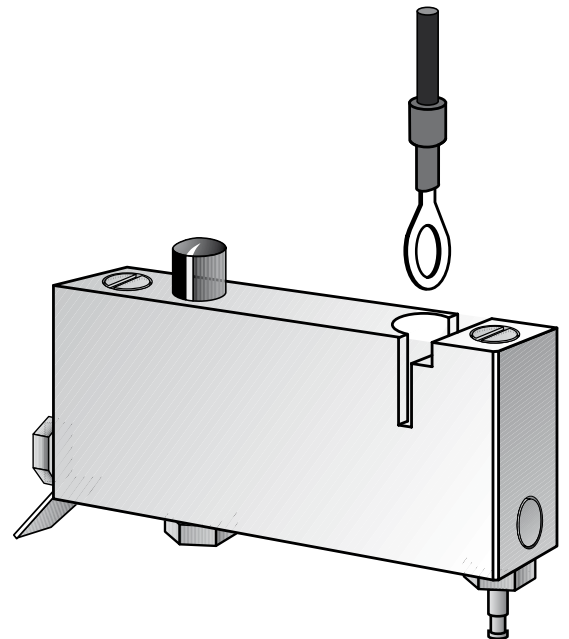

Please take note of our special accessories such as pneum. central opener, compressed air distributor.